

3

Cells

- ◆ How cells were discovered
- ◆ The microscope
- ◆ The basic parts of a cell
- ◆ Adaptations in cells

In Chapter 2, we saw how the body is divided into systems of organs. In this chapter, we are going to find out what organs are made from.

From organs to cells

In the 16th century, scientists in Europe began studying the human body by dissection. This work has continued ever since.



Figure A This painting by Rembrandt shows Dr Nicolaes Tulp making a dissection, in Holland in 1632.



● BIOLOGY

Marie-François X. Bichat (1771–1802) was a French doctor who did many post mortem examinations. In the last year of his life, he carried out 600. He cut up the bodies of dead people to find out how they had died. From this he discovered that organs were made of layers of materials. He called these layers 'tissues' and identified 21 different kinds. For a while, scientists thought that tissues were made of simple non-living materials.

In 1665, long before Bichat was born, an English scientist named Robert Hooke (1635–1703) used a microscope to investigate the structure of a very thin sheet of cork. He discovered that it had tiny compartments in it. He thought of them as rooms and called them 'cells', after the small rooms in monasteries where monks worked and meditated.

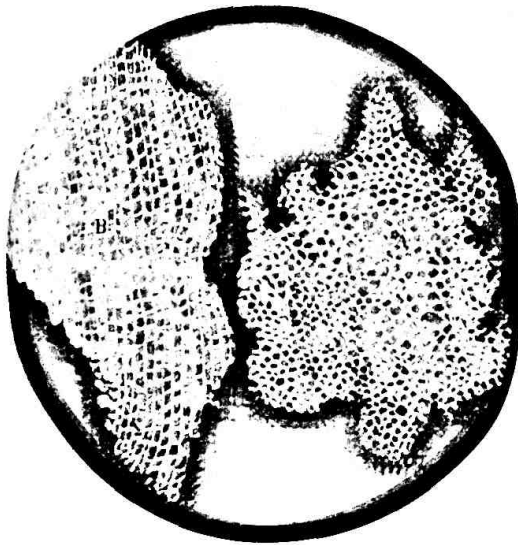



Figure B Here are the compartments in cork that Hooke saw using his microscope. He called them cells.

Bichat did not examine the tissues he had found under a microscope because most of those made at that time did not produce very clear images. When better microscopes were made, scientists investigated pieces of plants and found that, like cork, they also had a cell structure. The cells in Hooke's piece of cork had been empty but other plant cells were found to contain structures.

A Scottish scientist called Robert Brown (1773–1858) studied plant cells and noticed that each one had a dark spot inside it. In 1831, he named the spot the nucleus, which means 'little nut'.

Matthias Schleiden (1804–1881) was a German scientist who studied the parts of many plants and in 1838 he put forward a theory that all plants were made of cells. A year later Theodor Schwann (1810–1882), another German scientist, stated that animals were also made of cells.

The ideas of Schleiden and Schwann became known as the Cell Theory. It led other scientists to make more discoveries about cells and to show that tissues are made up of groups of similar cells.

- 1 Where did Bichat get his ideas that organs were made from tissues?
- 2 Who first described 'cells' and where did the idea for the word come from?
- 3 Who named the nucleus and what does the word mean?
- 4 What instrument was essential for the study of cells?
- 5 How could the Cell Theory have been developed sooner?
- 6 Arrange these parts of a body in order of size starting with the largest: cell, organ, tissue, organ system.
- 7 Which scientific activity  did Bichat perform to think up his idea that organs were made from tissues?
- 8 Which was the final scientific activity that led Schleiden and Schwann to set up their Cell Theory?

The microscope

Most laboratory microscopes give a magnification up to about 200 times but some can give a magnification of over 1000 times. The microscope must also provide a clear view, and this is achieved by controlling the amount of light shining onto the specimen.

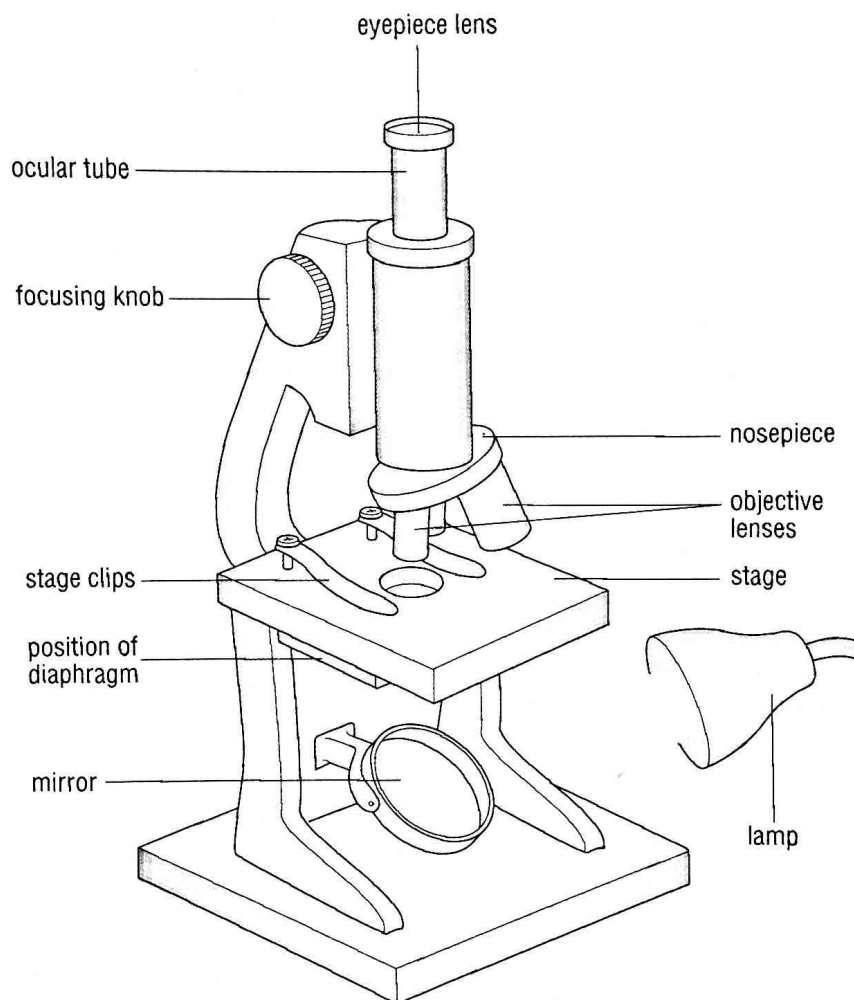

Figure 3.1 The main parts of a microscope

The microscope and light

Light is collected by a mirror at the base of the microscope. The mirror is held in special joints that allow it to move in any direction. The light comes from a lamp or from a sunless sky. It must never be collected directly from the Sun as this can cause severe eye damage and blindness. Some microscopes have a built-in lamp instead of a mirror. The light shines directly through a hole in the stage onto the **specimen**.

- 1 What is a microscope used for?
- 2 What advice would you give someone about how to collect light to shine into a microscope?

- 3 What magnification would you get by using an eyepiece of $\times 5$ magnification with an objective lens of $\times 10$ magnification?
- 4 If you had a microscope with $\times 5$ and $\times 10$ eyepieces and objective lenses of $\times 10$, $\times 15$ and $\times 20$, what powers of magnification could your microscope provide?
- 5 How would you advise someone to use the three objective lenses on the nosepiece?
- 6 Why should you not look down the microscope all the time as you try to focus the specimen?
- 7 Look at the picture of the microscope on page 47 and describe the path taken by light from the lamp near the microscope to the user's eye.
- 8 If there are about 6000 million people on the Earth, how many cells have you got in your body?

The magnification of the microscope

Above the stage is the ocular tube. This has an eyepiece lens at the top and one or more objective lenses at the bottom. The **magnification** of the two lenses is written on them. An eyepiece lens may give a magnification of $\times 5$ or $\times 10$. An objective lens may give a magnification of $\times 10$, $\times 15$ or $\times 20$. The magnification provided by both the eyepiece lens and the objective lens is found by multiplying their magnifying powers together.

Using the lenses

Most microscopes have three objective lenses on a nosepiece at the bottom of the ocular tube. The nosepiece can be rotated to bring each objective lens under the ocular tube in turn. An investigation with the microscope always starts by using the lowest-power objective lens, and then working up to the highest-power objective lens if it is required.

Putting the specimen under the microscope

A specimen for viewing under the microscope must be put on a glass slide. The slide is put on the stage and held in place by the stage clips. The slide should be positioned so that the specimen is in the centre of the hole in the stage.

Focusing the microscope

The view of the specimen is brought into focus by turning the focusing knob on the side of the microscope. This may raise or lower the ocular tube, or it may raise or lower the stage. In either case you should watch from the side of the microscope as you turn the knob to bring the objective lens and specimen close together. When the objective lens and the specimen are close together, but *not* touching, look down the eyepiece and turn the focusing knob so that the objective lens and specimen move apart. If you do this slowly, the blurred image will become clear.

Looking at cells

There are ten times more **cells** in your body than there are people on the Earth. If you stay in the water in a swimming pool for a long time you may notice sometimes that when you dry yourself part of your skin flakes off. These flakes are made of dead skin cells. You are losing skin cells all the time but in a much smaller way.

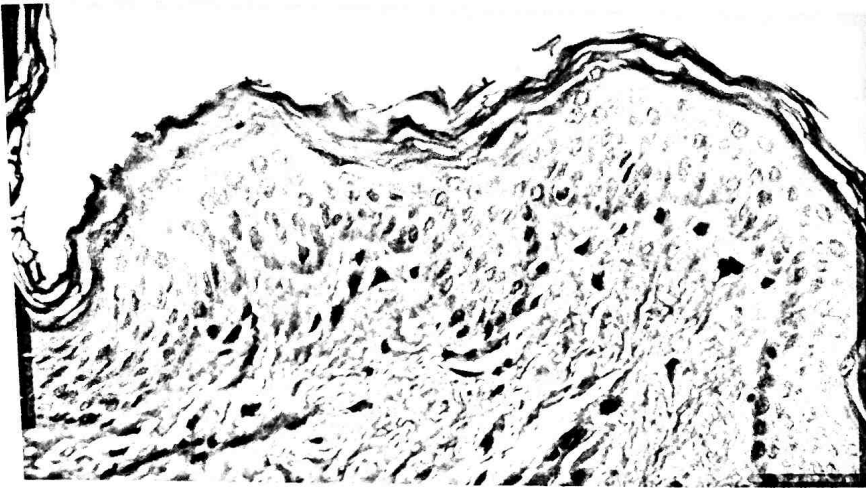

Figure 3.2 Section of human skin. Cells can be seen flaking off the surface.

As your clothes rub against your skin they pull off tiny flakes, which pass into the air and settle in the dust. A small part of the dirt that cleaners sweep up at the end of a school day comes from the skin that the students have left behind.

Figure 3.2 shows a section of human skin that has been stained and photographed down a microscope using a high-

power objective lens. When unstained, the different parts of the cells are colourless and are difficult to distinguish. In the 1870s, it was discovered that dyes could be made from coal tar which would stain different parts of the cell. Cell biologists found they could stain the nucleus and other parts of the cell different colours to see them more easily.

- 9 Why are most specimens of cells stained before they are examined under the microscope?

Basic parts of a cell

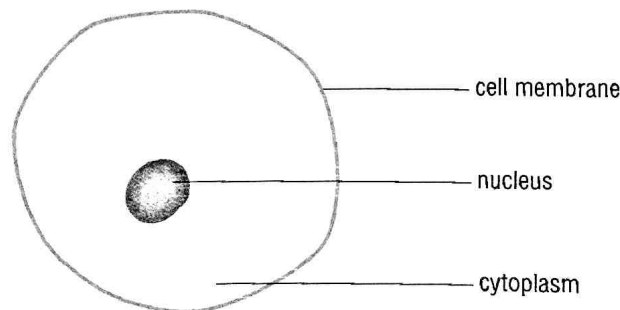

Figure 3.3 A typical animal cell

Nucleus

The **nucleus** is the control centre of the cell. It contains the **genetic material**, called **DNA** (its full name is deoxyribonucleic acid). DNA is made from groups of **atoms** linked together to form a **molecule** like a long chain. The groups of atoms occur in different combinations along the DNA molecule. The combinations of the groups provide instructions for the cell to make chemicals to keep it alive or to build its cell parts. As a cell grows the DNA is copied, and when the cell divides the DNA divides too, so that the nucleus of each new cell receives all the instructions to keep the new cell alive and enable it to grow.

- 10 Imagine that you are looking down a microscope at a slide labelled 'Cells'. You can see a coloured substance with dots in it and lines that divide the substance into rectangular shapes. What are:
- a) the dots
 - b) the lines
 - c) the coloured substance?
- 11 How does the cell membrane protect the cell?

Cytoplasm

Cytoplasm is a watery jelly that fills most of each animal cell. It can move around inside the cell. The cytoplasm may contain stored food in the form of grains. Most of the chemical reactions that keep the cell alive take place in the cytoplasm.

Cell membrane

The **cell membrane** covers the outside of the cell. It has tiny holes in it called pores that control the movement of chemicals in or out of the cell. Dissolved substances such as food, oxygen and carbon dioxide can pass through the cell membrane. Some harmful chemicals are stopped from entering the cell by the membrane.

Parts found only in plant cells

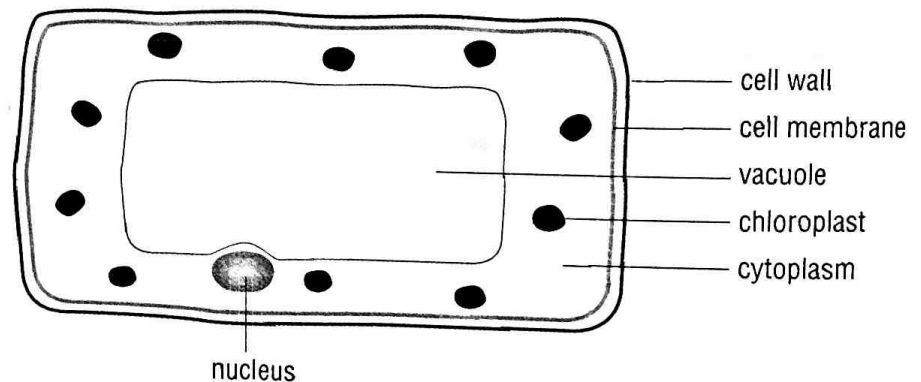

Figure 3.4 A typical plant cell

Cell wall

The **cell wall** is found outside the membrane of a plant cell. It is made of **cellulose**, which is a tough material that gives support to the cell.

Chloroplasts

Chloroplasts are found in the cytoplasm of many plant cells. They contain a green pigment, called **chlorophyll**, which traps a small amount of the energy in sunlight. This energy is used by the plant to make food in a process called photosynthesis. (You will learn more about photosynthesis later in the course.) Chloroplasts are found in many leaf cells and in the stem cells of some plants.

- 12 Name two things that give support to a plant cell.
- 13 Would you expect to find chloroplasts in a root cell? Explain your answer.
- 14 Why do plants wilt if they are not watered regularly?

Large vacuole

The **vacuole** is a large space in the cytoplasm of a plant cell that is filled with a liquid called cell sap containing dissolved sugars and salts. When the vacuole is full of cell sap the liquid pushes outwards on the cell wall and gives it support. If the plant is short of water, the support is lost and the plant wilts.

Some animal cells and **Protoctista** (page 60) have vacuoles but they are much smaller than in plant cells.

Adaptation in cells

The word **adaptation** means the change of an existing design for a particular task (see also page 75). You learnt about the basic structures of animal and plant cells in the last section, but many cells are adapted, which allows them to perform a more specific task. Here are some common examples of the different types of animal and plant cells.

Red blood cells

Red blood cells are disc-shaped but their centres dip inwards. The structure is called a biconcave disc. Red cells only have a nucleus when they are growing. They lose it so that they can become packed with haemoglobin when they are fully grown. **Haemoglobin** combines with oxygen in the lungs to form oxyhaemoglobin. The red blood cells carry this substance to parts of the body where oxygen is needed. When the cells reach their destination, they release the oxygen. Haemoglobin forms again, ready for another trip to the lungs.

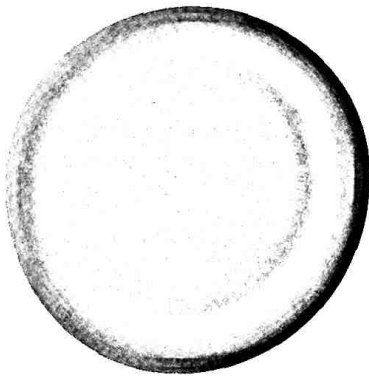

Figure 3.5 Red blood cell

White blood cells

White blood cells have an irregular shape. In fact, they keep changing shape as the cytoplasm flows about inside them. One kind of white cell, a lymphocyte, produces antibodies, which attack harmful microorganisms in the blood, such as bacteria. A second kind of white cell, a phagocyte, eats the harmful microorganisms.

- 15 In what ways are red and white blood cells different?

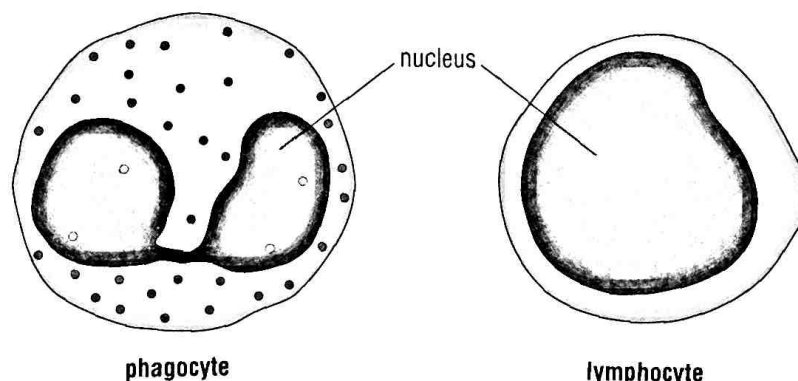

Figure 3.6 White blood cells

Smooth muscle cells

Once you swallow food, it is moved through your alimentary canal by smooth muscle cells. These cells are spindle-shaped and lie together forming muscular tissue around the wall of the oesophagus, stomach and intestines. Muscle cells can only use their energy to contract or get shorter; they need other muscles to stretch them back to their original length. For this reason, smooth muscle cells are arranged in layers at right angles to each other. When the cells in one layer contract, they squeeze food through your body. When the cells in the next layer contract, they stretch the muscles in the first layer so they can contract again and move more food.

16 What happens to the smooth muscle cells in the outer layer in Figure 3.7 when the muscle cells in the inner layer are contracting just behind the ball of food?

Figure 3.7 The arrangement of smooth muscles in the oesophagus

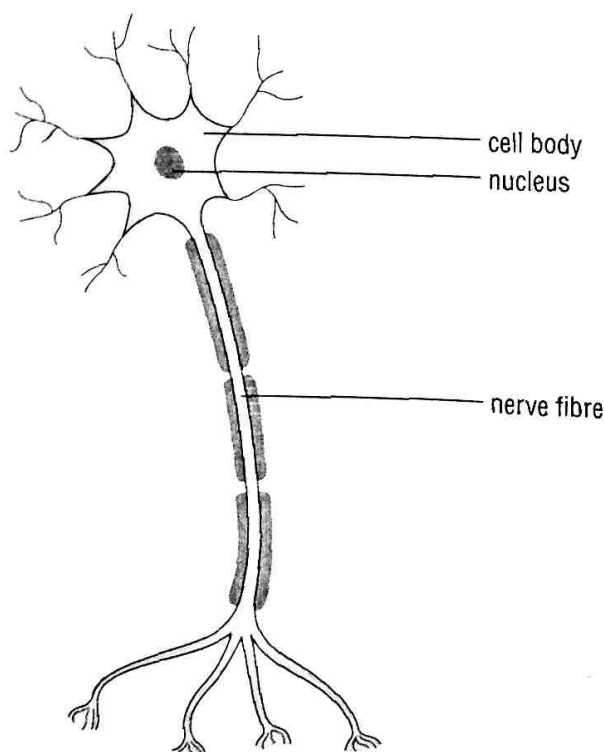
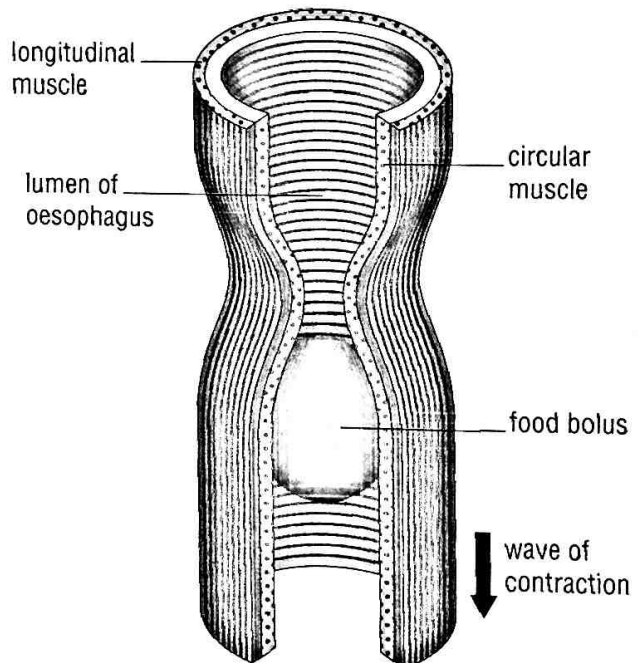

Figure 3.8
Nerve cell

Nerve cells

Nerves are made from nerve cells or **neurones**, which have long, thread-like extensions. These nerve cells are connected to other nerve cells in the spinal cord. The nerve cells in the spinal cord are then connected to nerve cells in the brain.

- 17 Smoking damages the cilia lining the breathing tubes. What effect might this have on breathing?

Ciliated epithelial cells

Cells that line the surface of structures are called **epithelial cells**. **Cilia** are microscopic hair-like extensions of the cytoplasm. If cells have one surface covered in cilia, they are described as ciliated. Ciliated epithelial cells line the throat. Air entering the throat contains dust that becomes trapped in the mucus of the throat lining. The cilia wave to and fro and carry the dust trapped in the mucus away from the lungs.

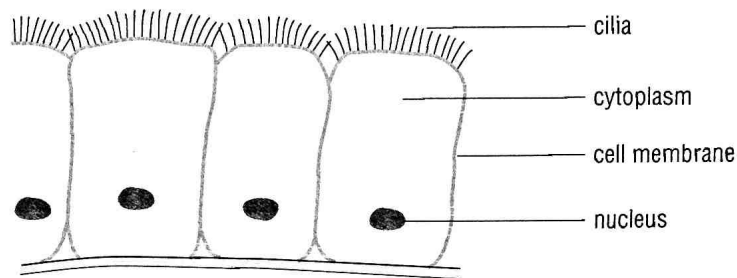

Figure 3.9 Ciliated epithelial cells

Root hair cells

Root hair cells are plant cells that grow a short distance behind the root tip. The cells have long, thin extensions that allow them to grow easily between the soil particles. The shape of these extensions gives the root hair cells a large surface area through which water can be taken up from the soil.

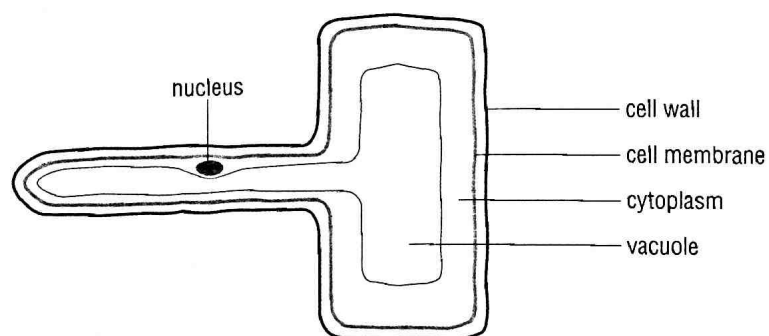

Figure 3.10 A root hair cell

- 18 What changes have taken place in the basic plant cell to produce a root hair cell?
- 19 Why would it be a problem if root hair cell extensions were short and stubby?

Palisade cells

Palisade cells (Figure 3.11) have a shape that allows them to pack closely together in the upper part of a leaf, near the light. They have large numbers of chloroplasts in them to trap as much light energy as possible.

- 20** How is a palisade cell different from a root hair cell? Explain these differences.
- 21** Why are there different kinds of cells?

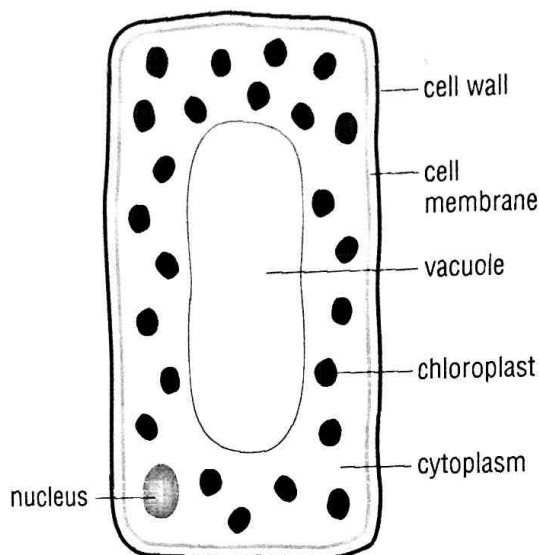

Figure 3.11 A palisade cell

Cells, tissues, organs and organisms

Cells in a living thing are arranged into groups. The cells in a group are all the same kind and perform a special task in the life of the organism. This group of cells is called a **tissue**. Different tissues join together to make a larger group of cells called an **organ**. All the special tasks performed by the cells in the different tissues in the organ help the organ to keep the body alive. Organs can form groups called **organ systems**. The organs in a system perform a vital task in the survival of the body – related to the seven life processes (see page 21). All the organs and organ systems in a living thing form a larger group – the body of the living thing – which is known as a living **organism**.

Plants as living organisms

The cells which form the outer covering of a plant are broad and flat and join together to form a tissue called the **epidermis**. In a leaf, they cover a layer of palisade cells, which form a tissue called **palisade mesophyll**. The purpose of this tissue is to collect light and make food.

Beneath this tissue are rounder-shaped cells with gaps between them, which form the **spongy mesophyll** tissue. Their task is to help bring water to the leaf for use in making food. Water evaporates from their surfaces and is replaced by water drawn up in tube-like **xylem tissue**, which forms much of the mid rib and veins in the leaf.

Specialised pairs of cells in the lower epidermis of a leaf can bend to make an opening through which water vapour can escape from the spongy mesophyll. These openings are called stomata (*singular: stoma*).

Figure 3.12 This section through a leaf shows the different tissues that work together. The cells in the epidermis form a protective surface like tiles on a roof.

- 22** Make a chart to show how different types of plant cells form tissues, which in turn form an organ. You could make a table of three columns with the headings Cells, Tissues and Organ to help you and make one or more drawings in each column. Give your chart a title, such as 'The tissues of a leaf'.

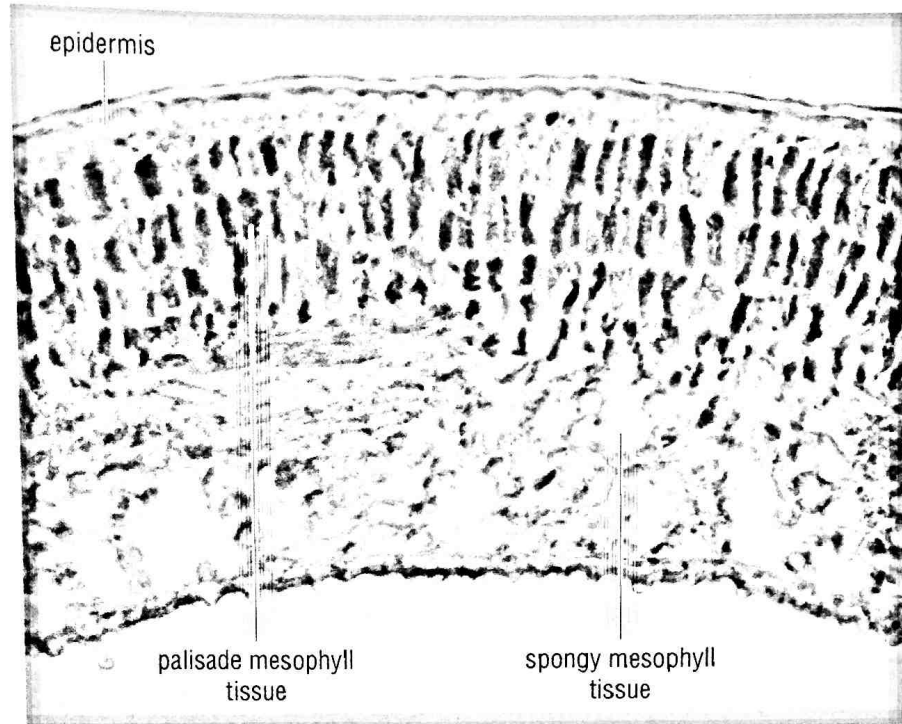

The tissues in the leaf work together and form an organ – the leaf – which makes food for the plant. Epidermis and xylem tissues join with other tissues to make other organs of the plant such as the root, stem, bud and flower. Together all the organs make up the organism – the plant.

Animals as living organisms

There are many kinds of cells in animals' bodies and they form many kinds of tissues. These in turn form groups to make organs, systems and the organism itself – the animal.

For example, the stomach is an organ that stores and digests food. It can be thought of as a muscular bag, which churns up food in the digestion process, but it is made of more than just muscle cells.

Figure 3.13 The stomach wall is made of many different tissues of cells.

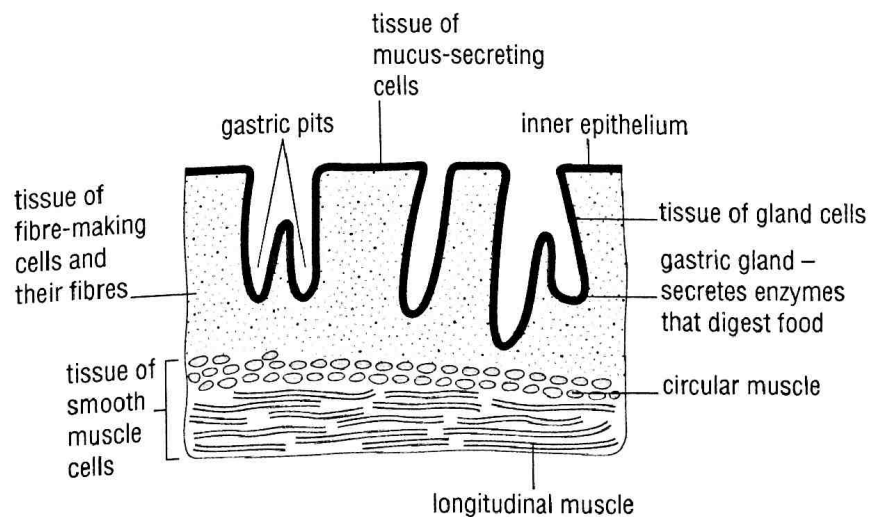

The inner surface of the stomach is lined with a tissue of epithelial cells that **secrete** mucus, which helps the food slide by. There are cavities in the lining called gastric pits where tissues of gland cells secrete digestive juices to break down the food. The epithelial and gland cells are supported by a layer of fibres made from fibre-making cells. This layer connects to the layers of smooth muscle tissue.

All these tissues form the structure called the stomach, and this in turn is connected to the other digestive organs (see page 40) to form the digestive system. This system is very closely linked to other systems such as the circulatory system, where blood vessels in the intestine take away absorbed food and carry it around the body. The group of closely linked organ systems form the organism – the animal.

23 What is the connection between a cell and an organism?

◆ SUMMARY ◆

- ◆ The bodies of plants and animals are made of cells. The basic parts of the cell are the nucleus, cytoplasm and cell membrane (*see page 49*).
 - ◆ In a plant cell, there is a cellulose cell wall and a vacuole (*see page 50*).
 - ◆ Cells have different forms for different functions. They are adapted to do specific tasks in the body and life of the organism (*see page 51*).
 - ◆ Cells are grouped together into tissues. Tissues are grouped together to make organs (*see page 54*).
 - ◆ A number of organs that work together is called an organ system (*see page 54*).
-
-

End of chapter questions

- 1** Which part of a cell:
- a)** has pores that control the movement of chemicals
 - b)** is made from cellulose
 - c)** contains DNA
 - d)** contains chlorophyll
 - e)** is made from watery jelly
 - f)** contains cell sap?
- 2** Which of the cell parts in question **1** are found only in plant cells?